

PRESSURE REDUCING VALVE FOR WATER

DZR BRASS VA1072 CR PN25



Direct acting pressure reducing valve piston operating with pressure compensation system

Main body and components made in brass alloy in conformity to UBA

PN 25 – Max inlet pressure 25 bar

Outlet pressure range 1 – 6 bar / reduction ratio: 5:1

Factory setting 3 bar

Maximum working temperature : 80° C

Stainless steel seat

Stainless steel bar (sizes higher than 1")

NBR /EPDM rubber parts

Designed for use with water and air

Pressure gauge connections ¼"

Threaded FF ISO 228

Available sizes: from 2/1" (DN15) to 4" (DN100)

External sand blasted brass

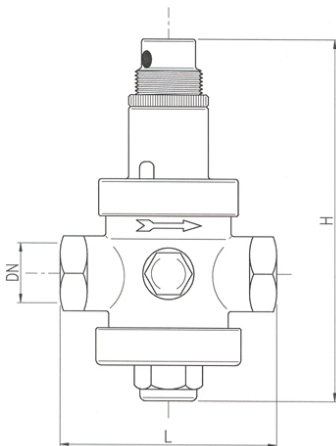

Item N	Size	DN	H mm	L mm	Weight Gr
143.12 .BG	½"	15	120	75	890
143.34 .BG	¾"	20	122	76	860
143.33 .BG	1"	25	160	90	1.340
143.114 .BG	1¼"	32	220	115	2.090
143.112 .BG	1½"	40	220	125	2.180
143.58 .BG	2"	50	250	140	3.100
143.160 .BG	2½"	65	260	148	4.100
143.80 .BG	3"	80	285	177	5.520
143.100 .BG	4"	100	310	190	6.970

Notes

Designs, materials and specifications shown are subject to change without notice due to the continuous development of our products.

FLOW RATE vs PRESSURE DROP CHART:

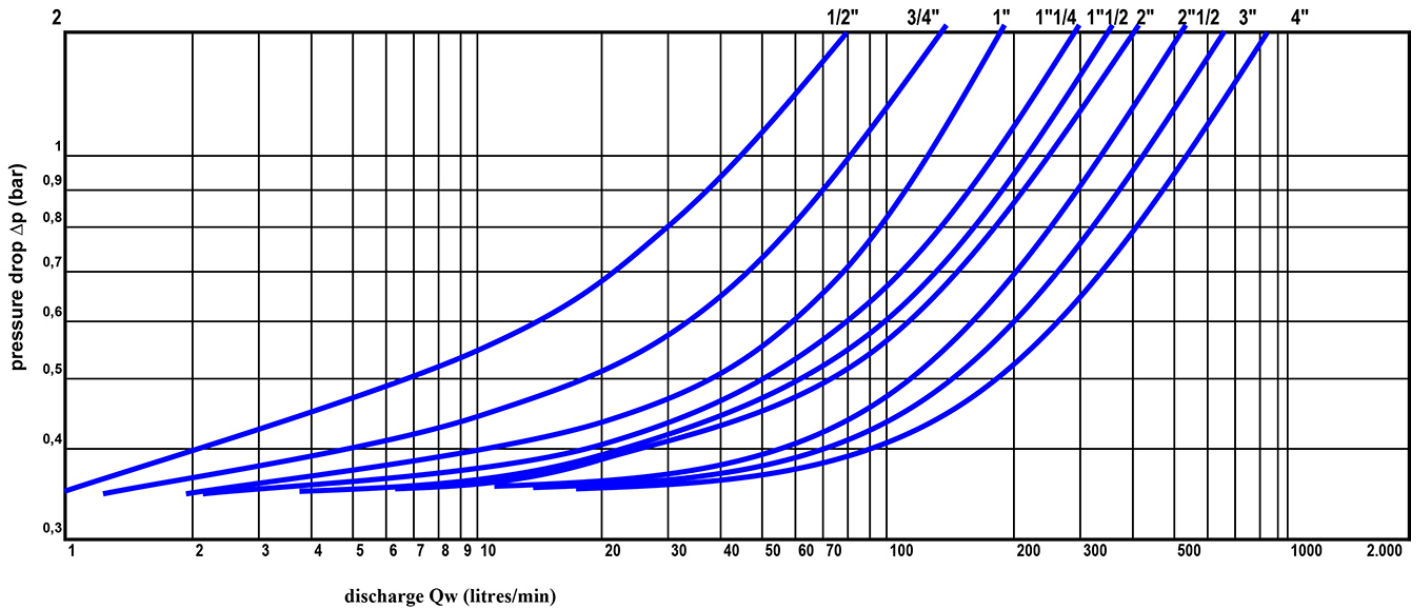

FLOW vs FLOW CHART:

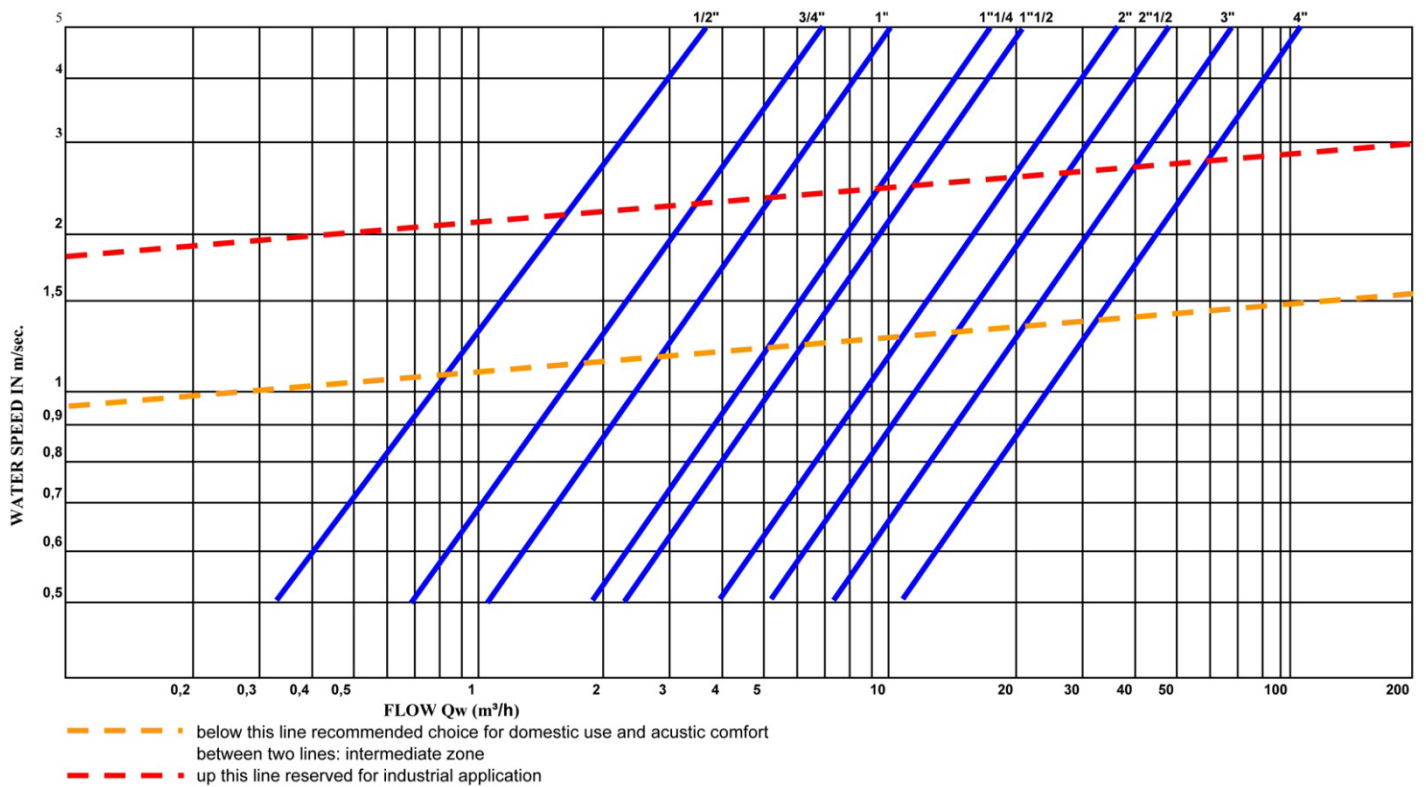

Notes

Designs, materials and specifications shown are subject to change without notice due to the continuous development of our products.

CAVITATION CHART:

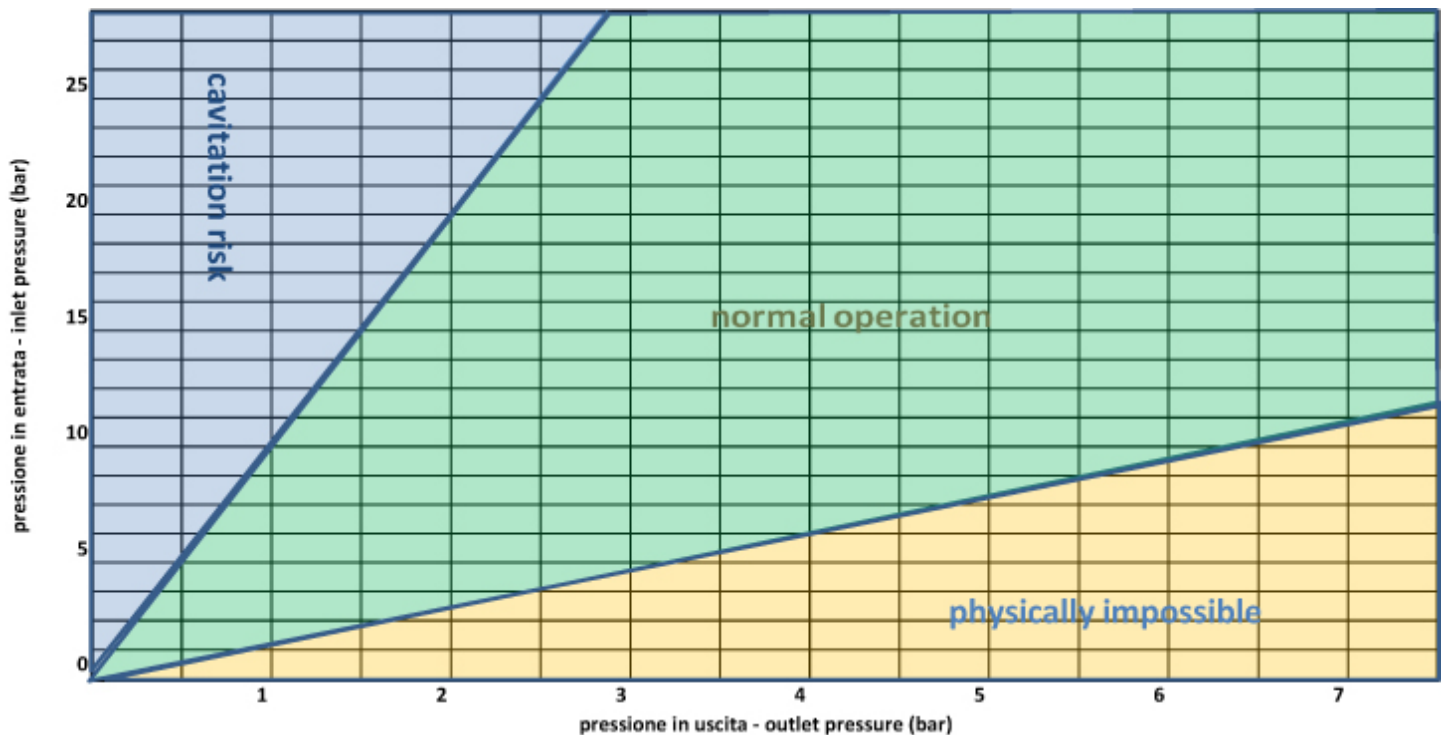

BEST HYDRAULIC DISCHARGE OF PRESSURE REDUCERS DZR BRASSR 143

In order to choose the best pressure reducers for any plant, we suggest to follow the indications mentioned in the underexposed table with the best running pressure of the valves DZR BRASS 143; the values are exposed both in litres/minute and cbm/hour, and indicate the field of use where you can obtain the best functioning, silence and smaller loss of charge of the valves.

MODEL	SIZE	AVERAGE HYDRAULIC DISCHARGE L/min	AVERAGE HYDRAULIC DISCHARGE Cbm/hour
DZR BRASS 143	8/3"	15 - 30	0,9 - 1,8
DZR BRASS 143	1/2"	20 - 50	1,2 - 3
DZR BRASS 143	3/4"	50 - 75	3 - 4,5
DZR BRASS 143	1"	75 - 95	4,5 - 6
DZR BRASS 143	1" 1/4	95 - 130	6 - 8
DZR BRASS 143	1" 1/2	110 - 140	7 - 8,5
DZR BRASS 143	2"	120 - 160	7,5 - 10
DZR BRASS 143	2" 1/2	140 - 180	8,5 - 11
DZR BRASS 143	3"	160 - 220	10 - 13,2
DZR BRASS 143	4"	200 - 260	12 - 15,6

Notes

Designs, materials and specifications shown are subject to change without notice due to the continuous development of our products.

INSTALLATION GUIDELINES

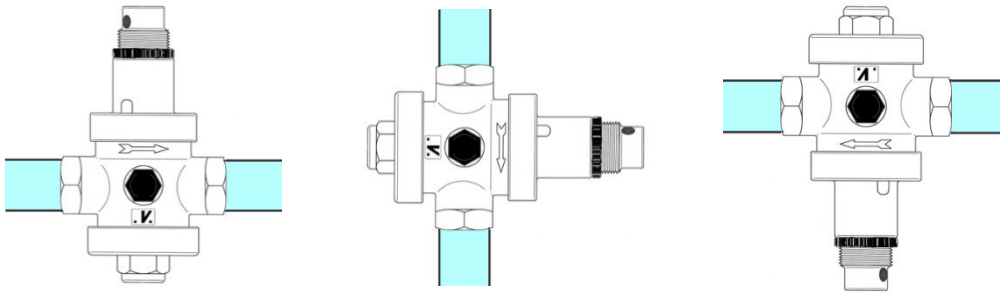

The pressure reducers DZR BRASS 143 don't get the effects, in their functioning, of gravity force; therefore they can be installed in the plant in any position :

Pressure reducing valves can be damaged by dirty water; therefore we advise to install a self-cleaning filter upstream before the pressure reducer, in order to protect the valve and any other mechanism (thermostatic mixers, taps, etc.).

When there is a device which produce or store hot water or pipes are exposed to sudden changes in temperature, an increase of outlet pressure may occur; this event is due to the raise in pressure that follows the temperature rising: an expansion vessel between downstream the pressure reducing valve will avoid this problem.

We recommend moreover to install a Stopshock valve to prevent water hammer which would damage the inner parts of the pressure reducer and other devices in the waterworks

Recommended installation :

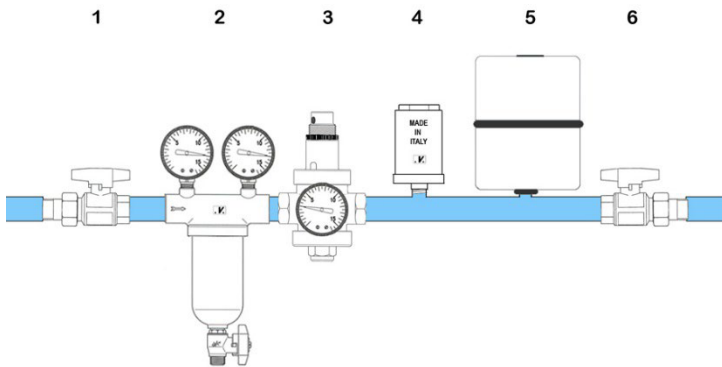

- 1 – ball valve
- 2 – Self-cleaning filter
- 3 – Pressure reducing valve
- 4 – Water hammer absorber
- 5 – Expansion tank
- 6 – ball valve



All VANTEC pressure reducers are tested before being packaged; during test they are pre-set at the outlet pressure of 3 bars ; outlet pressure can be easily adjusted once the pressure reducing valve is installed on site.

In order to modify the outlet pressure, once removed the seal, you should only loosen the fixing ring and turn the spring holder as indicated in the pictures sequence. By turning clockwise the pressure increases, while counter-clockwise the pressure decreases. A right setting should be made while the plant outlet is closed.

⚠WARNING: Installation or any change of outlet pressure must be performed by qualified personnel .

Notes

Designs, materials and specifications shown are subject to change without notice due to the continuous development of our products.